

INSTRUCTION BULLETIN
USER'S GUIDE

CyTimeTM
Sequence of Events Recorder
SER-32e Relay Output Module
(eXM-RO-08)

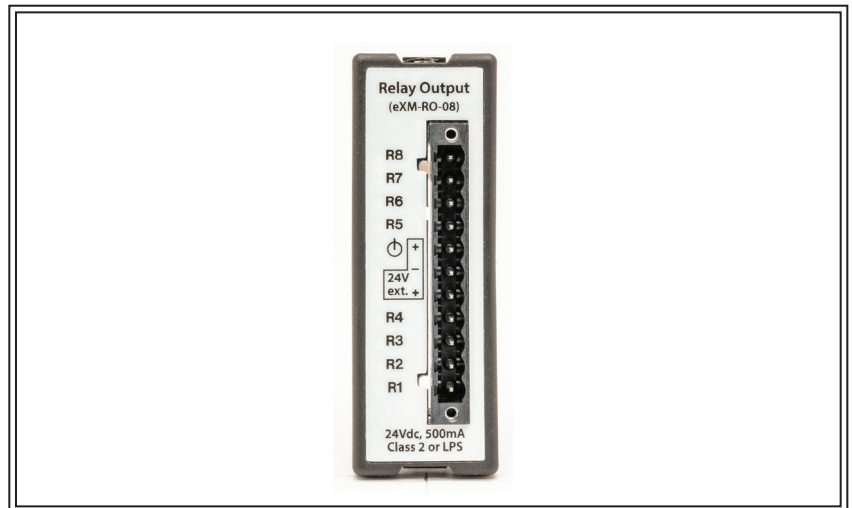
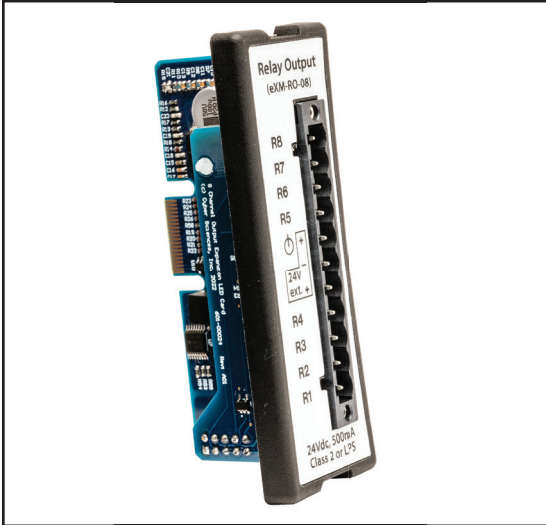

TABLE OF CONTENTS



1—INTRODUCTION	1
Product Overview of SER-32e	1
Benefits of SER-32e	2
Key Features of SER-32e	3
Introduction to Relay Output Module	4
Overview	5
Ordering Information	5
2—INSTALLATION	6
Dimensions	6
Mounting / Installation	6
3—WIRING	7
Basic Wiring	7
4—OPERATION	8
Output Channels	8
5—SETUP (WEB SERVER)	9
Output Setup	9
Configuration Settings	9
6—PRODUCT SPECIFICATIONS	10
7—TROUBLESHOOTING	11

SAFETY PRECAUTIONS

Important safety precautions must be followed before attempting to install, service, or maintain electrical equipment. Carefully read and follow the safety precautions outlined below.

NOTE: *Electrical equipment should be serviced by qualified personnel. No responsibility is assumed by Cyber Sciences, Inc. for any consequences arising out of the use of this material. This document is not intended as an instruction manual for untrained persons.*

DANGER

HAZARD OF ELECTRIC SHOCK, EXPLOSION, OR ARC FLASH

- Only qualified workers should install this equipment. Such work should be performed only after reading this entire set of instructions.
- NEVER work alone.
- Before performing visual inspections, tests, or maintenance on this equipment, disconnect all sources of electric power. Assume that all circuits are live until they have been completely de-energized, tested, and tagged. Pay particular attention to the design of the power system. Consider all sources of power, including the possibility of backfeeding.
- Apply appropriate personal protective equipment (PPE) and follow safe electrical practices. For example, in the USA, see NFPA 70E.
- Turn off all power supplying the equipment in which the device is to be installed before installing and wiring the device.
- Always use a properly rated voltage sensing device to confirm that power is off.
- Beware of potential hazards, wear personal protective equipment, and carefully inspect the work area for tools and objects that may have been left inside the equipment.
- The successful operation of this equipment depends upon proper handling, installation, and operation. Neglecting fundamental installation requirements may lead to personal injury as well as damage to electrical equipment or other property.

Failure to follow these instructions can result in death or serious injury.

NOTICE

FCC (Federal Communications Commission)

This equipment has been tested and found to comply with the limits for a Class A digital device, pursuant to part 15 of the FCC Rules. These limits are designed to provide reasonable protection against harmful interference when the equipment is operated in a commercial environment. This equipment generates, uses and can radiate radio frequency energy and, if not installed and used in accordance with the instruction manual, may cause harmful interference to radio communications. Operation of this equipment in a residential area is likely to cause harmful interference in which case the user will be required to correct the interference at his own expense. The user is cautioned that any changes or modifications not expressly approved by Cyber Sciences, Inc. may void the user's authority to operate the equipment.

The Class A digital apparatus complies with CISPR 11, Class A, Group 1 (EN 55011) and Canadian ICES-003. (EN 61326-1) L'appareil numérique de classe A est conforme aux normes CISPR 11, classe A, groupe 1 (EN 55011) et à la norme Canadienne ICES-003. (EN 61326-1)

1—INTRODUCTION

Product Overview (SER-32e)

Note: The Cyber Sciences Relay Output Module is an optional addition to the CyTime™ SER-32e Sequence of Events Recorder. For more information on the SER-32e Sequence of Events Recorder, visit www.cyber-sciences.com/our-support/tech-library.

SER-32e User’s Guide

SER-32e Reference Guide

Sequence of Events Recorder Overview (SER-32e): The CyTime™ Sequence of Events Recorder provides precise time-stamped event reporting for 32 channels to enable root-cause analysis and advanced system diagnostics.

Configurable event recording: Each input is individually configurable with digital filter, debounce and contact chatter functions to ensure reliable operation.

Event log: The CyTime SER records the date and time associated with all state changes to one (1) millisecond and stores up to 8192 events in non-volatile memory. Each event record contains the date/time stamp, event type, channel number and state, time quality, and unique sequence number.

Export events to Comma Separated Variable (CSV): An export button allows the user to save event data to a CSV file for further analysis in Excel® or other software.

EPSS data log groups: Inputs can be assigned to a group for data logging purposes. If any input in a group changes state, then the states of all group members are recorded in its EPSS data log. This enables specialized reporting for mandatory tests of emergency power supply systems (EPSS) to document compliance with standards for healthcare and other critical-power facilities.

Operations counters: Operations counters are maintained for all 32 channels (inputs), with date/time of last reset. Each channel can be reset individually.

Ethernet communications: Network data communications to a host system are supported via 10/100BaseTx Ethernet using Modbus TCP and/or RESTful web service. The device also features an embedded secure web server to simplify setup, operation, firmware updates and file transfers. In addition, PTP (Precision Time Protocol (IEEE 1588) or NTP (Network Time Protocol) can be used for time synchronization over Ethernet.

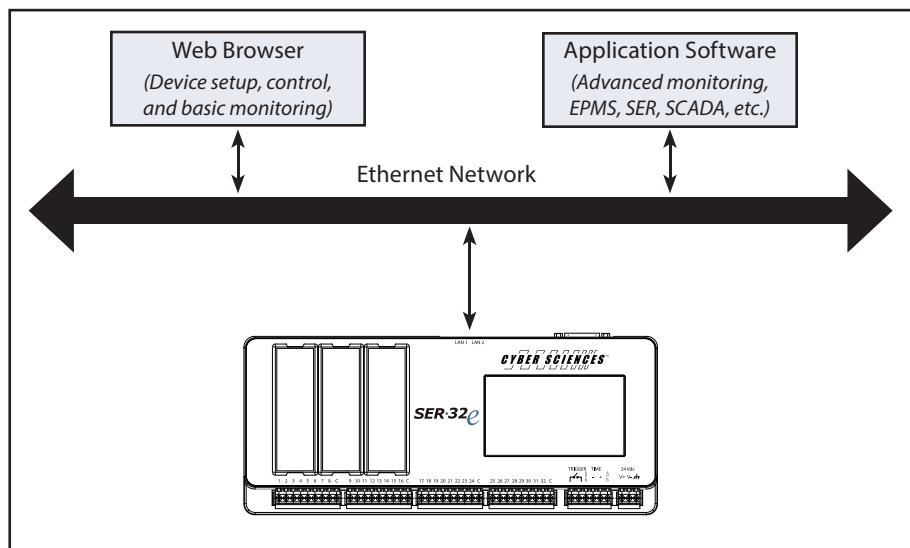

Figure 1-1. CyTime Sequence of Events Recorder SER-32e

Product Overview SER-32e (cont.)

Status monitoring examples:

- *Breaker status: open/closed/tripped*
- *Breaker control switch: open/close commands*
- *Relay trip signal: normal/trip*
- *Auto-transfer switch (ATS) status: normal/emergency/test*
- *Control scheme status: auto/manual/test*
- *UPS status: normal/bypass*
- *Generator status: stopped/running*
- *Battery status: normal/alarm*

Time synchronization (PTP). High-resolution time sync (100 μ s) is supported using PTP (Precision Time Protocol, per IEEE 1588) over the Ethernet network used for data communications. (Timestamps \pm 0.5 ms.) The SER-32e can be configured as the PTP master (grandmaster clock for all other SERs and PTP-compatible devices) or a PTP slave, synchronized to a PTP grandmaster (another SER or third-party clock).

Time synchronization (other protocols). Hi-res time sync (100 μ s) using 'legacy' protocols such as IRIG-B (unmodulated) or DCF77 is also supported. (Timestamps \pm 0.5 ms.) NTP or Modbus TCP time-sync are supported, but accuracy depends on network design and is typically \pm 100 ms or more.

Time-sync master. One SER can serve as a time-sync master to other devices via PTP or an RS-485 subnet. RS-485 serial protocol is either IRIG-B or DCF77 (per the input time source) or ASCII (selectable). When PTP or NTP is the time source, an SER can output IRIG-B, DCF77 or 1per10 using an optional interface (PLX-5V or PLX-24V).

Trigger output. Any input can be configured to close a high-speed output contact to trigger an associated action, such as a power meter's capture of voltage and current waveforms coincident with an event. The trigger occurs in the same millisecond interval during which the event is detected, with no filtering applied.

Multiple Modbus masters. The SER supports data access from multiple Modbus TCP masters (up to 44 simultaneous Modbus connections). This enables integration of multiple systems and flexibility in how application software manages sockets.

Settings stored in non-volatile memory. All settings are stored in non-volatile flash memory in XML file format. Configuration is accomplished using a standard web browser, or by modifying the setup file directly (by advanced users).

Benefits SER-32e

Benefits for end users, system integrators and OEMs include:

Time-critical information for root-cause analysis (1 ms)

Time-stamped record of events—up to 8192 events stored in non-volatile memory.

Reliable event recording with “zero blind-time”

Event-recording engine records all events, even those occurring in rapid succession.

Advanced troubleshooting

High-speed trigger output to capture waveforms by a compatible power meter.

Simple setup using a web browser—no proprietary software

Embedded web server hosts user-friendly pages for setup and monitoring.

No maintenance required

Event data and user setup data is stored in non-volatile flash memory.

Easy system integration

Integrate with multiple systems via Ethernet: Modbus TCP, RESTful API and secure web interface.

Flexible time synchronization choices

PTP, IRIG-B, DCF77, NTP, Modbus TCP or SER inter-device (RS-485).

EPSS generator test-compliance reports enabled

16 data logs: when any group member changes state, all members' states are recorded.

Easy replacement

If a unit ever needs to be replaced, settings are transferable via XML setup file.

Regulatory approvals to global standards

UL-Listed (UL/IEC 61010), CSA 22.2, CE, RoHS-compliant.

Key Features SER-32e

The CyTime SER-32e Event Recorder is designed to be mounted on a standard DIN rail, in an NRTL Enclosure. The table below gives a description of each key feature.

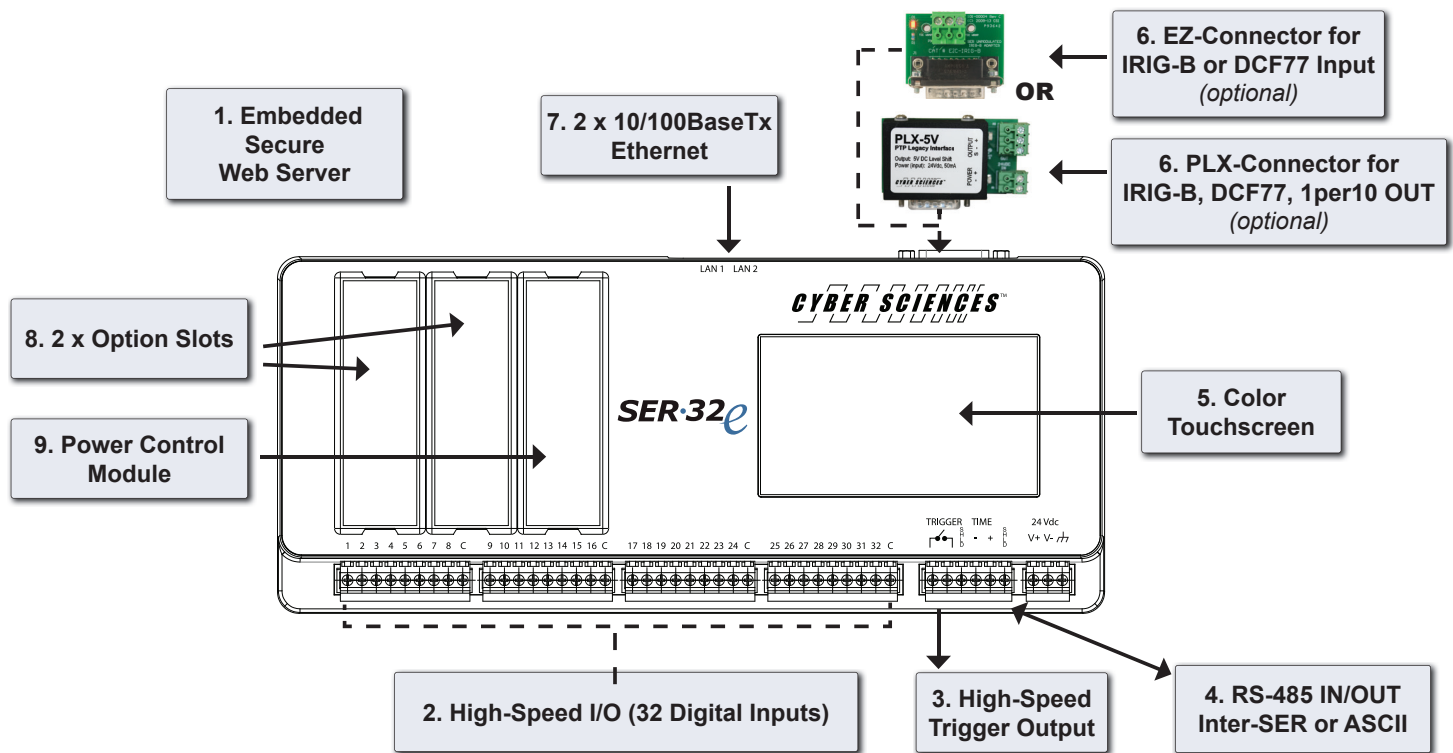
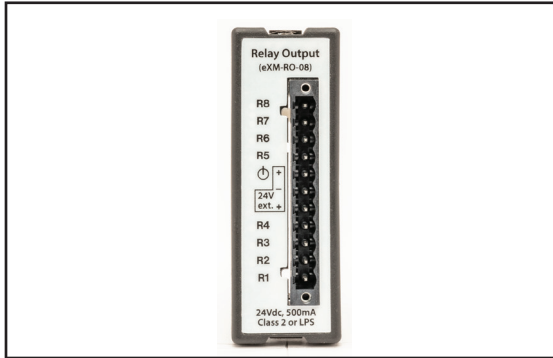

Figure 1-2. CyTime Event Recorder key features

Table 1-1—Key Features

Feature	Description
① Embedded Secure Web Server	Set up the device, monitor status, counters, diagnostics, and view event log records. Use web browser for firmware updates, manage security certificates, and upload/download configuration files.
② High-Speed I/O	32 digital inputs in four (4) groups of eight (8) inputs.
③ High-Speed Trigger Output	Digital output contact which can be configured to close momentarily on state change of one or more inputs to trigger an action, such as a waveform capture (WFC) by a compatible power meter.
④ Time Sync IN/OUT (RS-485)	Time sync OUT (when serving as a time-sync master to other devices) or time sync IN (when synchronized to another SER time-sync master) over RS-485 (2-wire plus shield). ASCII / RS-485 output is selectable.
⑤ Color Touchscreen	Color resistive touchscreen display (4.3" TFT, 480 x 272 pixels) for local access to status, events and setup parameters. User configurable brightness and screen saver.
⑥ EZC-IRIG-B/DCF77 (IN) or PLX-5V/PLX-24V (OUT)	DB-15-to-screw-terminal connector: EZ Connector (EZC) to accept IRIG-B or DCF77 time source (IN), or PLX (PLX-5V or PLX-24V) to output IRIG-B, DCF77 or 1per10 (OUT).
⑦ Ethernet Interface (10/100BaseTx)	Two Standard Ethernet RJ-45 network interface, with indicator LEDs for speed (10 or 100 Mbps) and link/activity. The SER auto-detects Ethernet wiring polarity and network speed.
⑧ Expansion Slots	Two expansion slots available for Digital Input and Relay Output expansion modules.
⑨ Power Control Module	Provides over 10 seconds of control power ride-through to ensure power system events are recorded. Includes replaceable battery for RTC (Real-Time Clock) backup.

Introduction Relay Output Module



The Relay Output Module is an optional accessory for the CyTime™ SER-32e Sequence of Events Recorder. Each output module provides eight (8) solid-state Form-A relay outputs. The SER-32e provides two (2) option slots allowing its native high-speed inputs to be complimented with up to sixteen (16) relay outputs for status indication and non-critical control applications. Outputs on the SER-32e and eXM-RO-08 are not recommended or intended for critical control applications.

Configurable event recording: Each output on the SER is individually configurable with Event logging enable, name, OFF text, ON text and to have its operation recorded in one or more Group logs.

Event log: The SER records the date and time associated with all output state changes to one (1) millisecond and stores up to 8192 events in non-volatile memory. Each event record contains the date/time stamp, event type, channel number and state, time quality, unique sequence number and delta time between recorded events.

EPSS data log groups: Inputs and outputs can be assigned to user defined groups for data logging purposes. If any input or output in a group changes state, the states of all group members are recorded in its EPSS (Group) data log. This enables specialized reporting for mandatory tests of emergency power supply systems (EPSS) to document compliance with standards for healthcare and other critical-power facilities.

Operations counters: Operations counters are maintained for all input and output channels, with date/time of last reset. Each channel can be reset individually.

Key features: The Relay Output Module provides eight (8) solid-state relay outputs to compliment the 32 high-speed inputs native to the SER-32e without the need for additional space or control power. These outputs can be useful for status indication and triggering operation of test and control sequences.

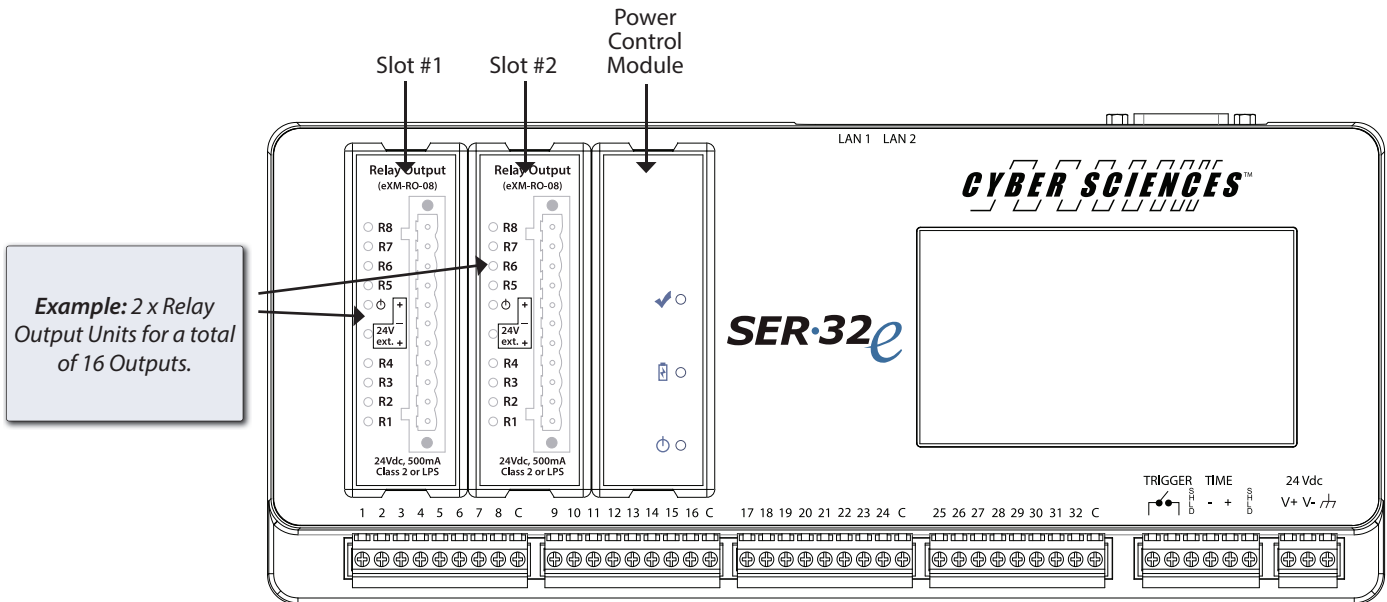

Figure 1-3. SER-32e with 2 x Relay Output Modules Added

Relay Output Module Overview

The Output Module provides 8 solid-state relay outputs, status indicators, an indicator for the presence of 24Vdc wetting voltage and an indicator for module control power and module status.

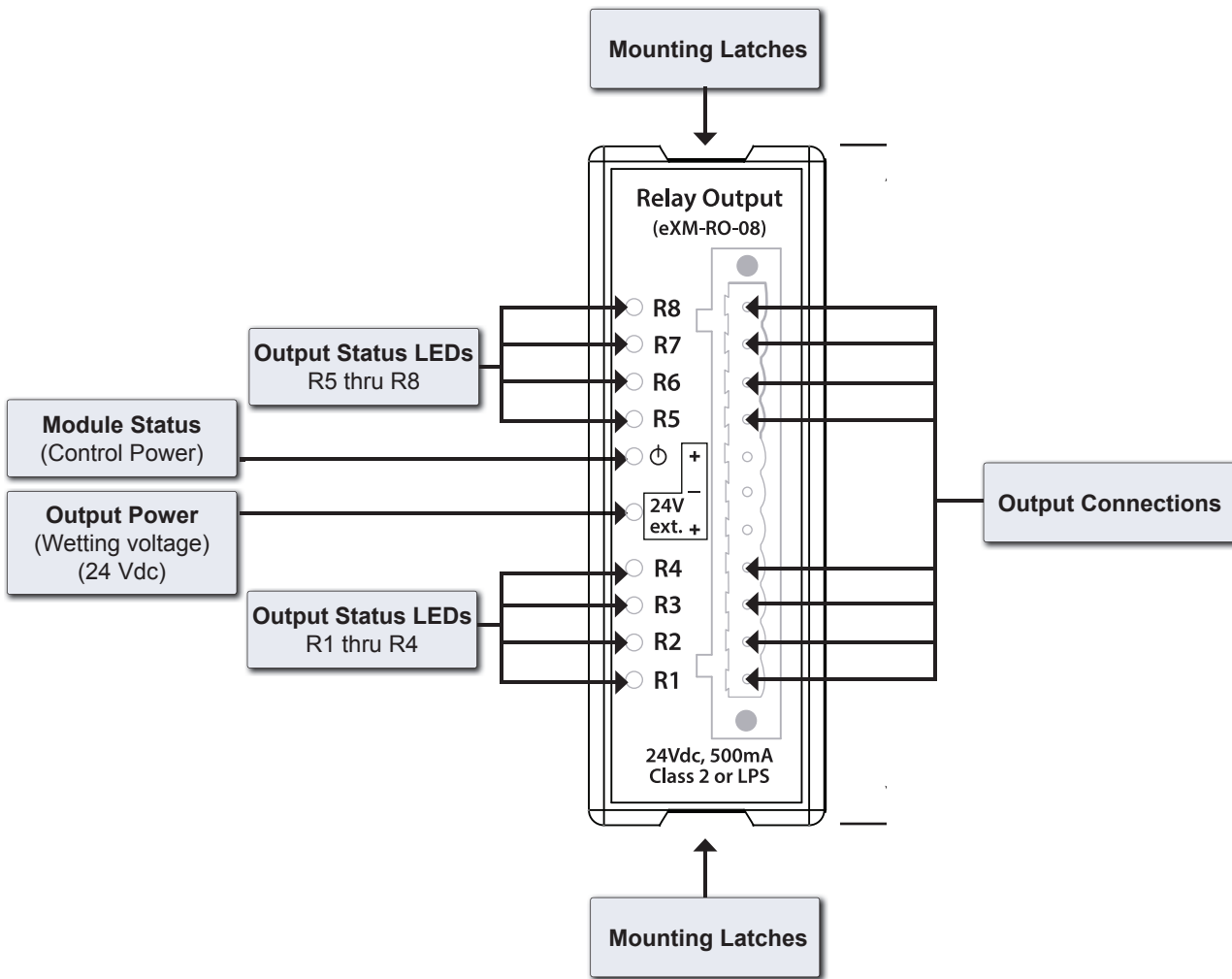

Figure 1-4. eXM-RO-08

Table 1-2—Ordering Information

Catalog Number	Description
SER-32e	CyTime Event Recorder, 32-input, PTP, secure web, 2x option slots, control power ride-thru
eXM-RO-08	8-output option module, 24 VDC, pluggable screw terminal connector
eXM-DI-08	8-input option module, 24 VDC, pluggable screw terminal connector
EZC-IRIG-B	EZ connector for SER (input: IRIG-B time source)
EZC-DCF77	EZ connector for SER (input: DCF77 time source)
PLXe-5V	PTP Legacy Interface, Self-Powered (5V DCLS, for unmodulated IRIG-B output)
PLX-5V	PTP Legacy Interface (5V DCLS, for unmodulated IRIG-B output)
PLX-24V	PTP Legacy Interface (DCF77, 1per10 or 24V IRIG-B output to STR-IDM)

2—INSTALLATION

Dimensions

The dimensions for the Relay Output Module are illustrated below.

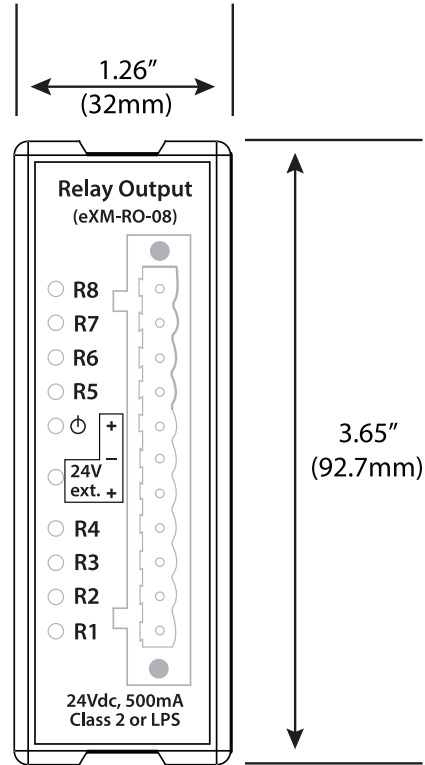

Figure 2-1. Relay Output Module Measurements

Mounting / Installation

Mounting Considerations

The Relay Output Module is designed to be mounted in one (1) of the two (2) option slots in the SER-32e. Connections are made to the front of the module using pluggable connectors.

Installing the Relay Output Module

The Relay Output Module is installed by inserting it into either of the two (2) option slots on the SER-32e (slot 1 or slot 2). (see figure 1-3)

Installation Procedure

- 1) Refer to Safety Precautions on page iv for electrical safety guidance, proper PPE and procedures.
- 2) Remove control power from the SER.
- 3) Monitor the LED indicators on the Power Control module until they are all OFF.
- 4) Remove the blank cover from the desired option module slot by pressing the two latches on the top and bottom of the cover and pull out.
We recommend retaining the cover for future use.
- 5) Align the output module in the guide rails with the connector on the right side of the module.
- 6) Insert the module into the option slot by pressing it into the SER until the latches “click” into place.
- 7) Reapply control power to the SER.
- 8) Confirm the SER recognizes the option module by viewing the Monitoring Status screen on either the SER display or web page.

3—WIRING

Wiring Connections for eXM-RO-08

The Relay Output Module has 8 solid-state relay outputs, each sharing a common return and requiring a 24 Vdc (Class 2 / LPS) wetting source, wired as shown below. Control power for the module is provided by the SER the module is mounted in. Each output is rated for 24 Vdc, 500 mA, maximum load. Recommended wiring for the outputs is Belden 8760 (18 AWG, shielded, twisted pair) cable, or equivalent.

Output connections are made via a removable screw terminal plug equipped with locking screws for mounting. It is recommended the locking screws be secured to ensure retention of the plug-in connector.

Refer to Safety Precautions on page iv for electrical safety guidance, proper PPE and procedures before wiring the input module.

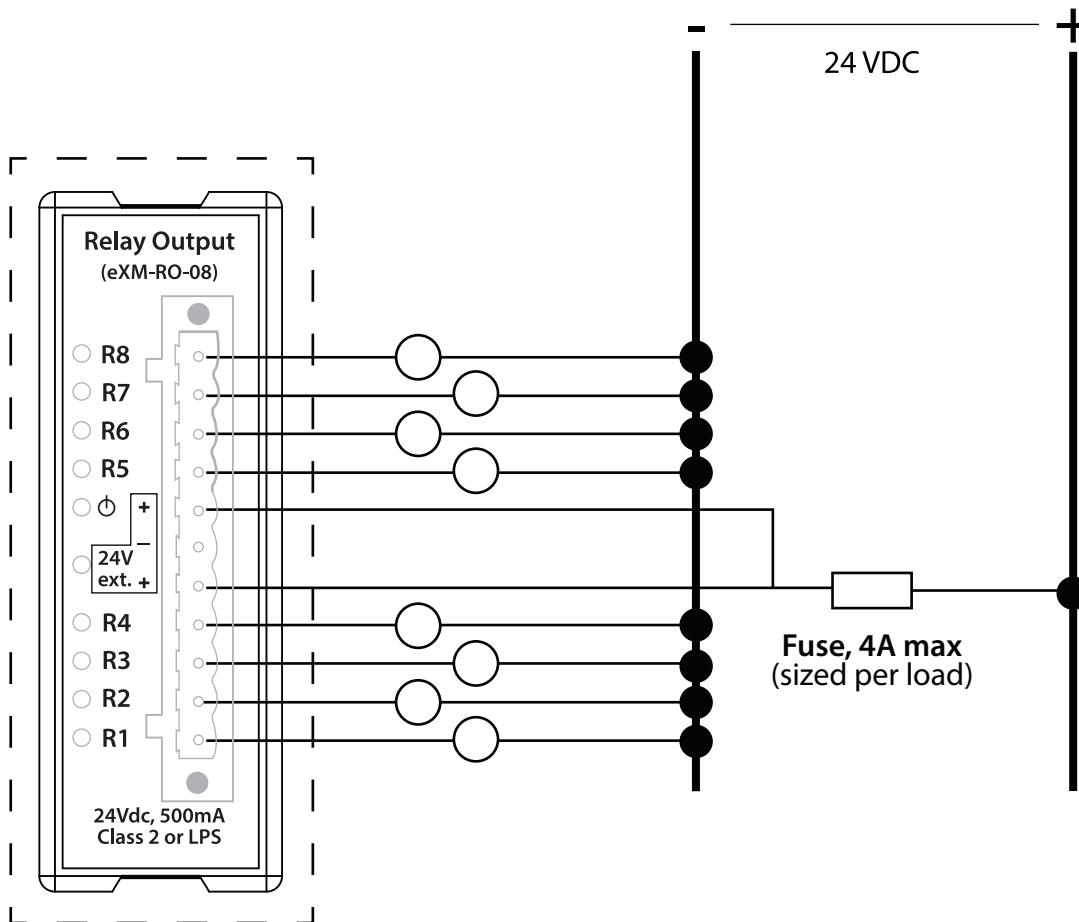

Figure 3-1. Relay Output Module Wiring

5—SETUP (WEB SERVER)

Output(s) Setup

Clicking “Outputs” under the Setup tab brings up the Output’s setup page:

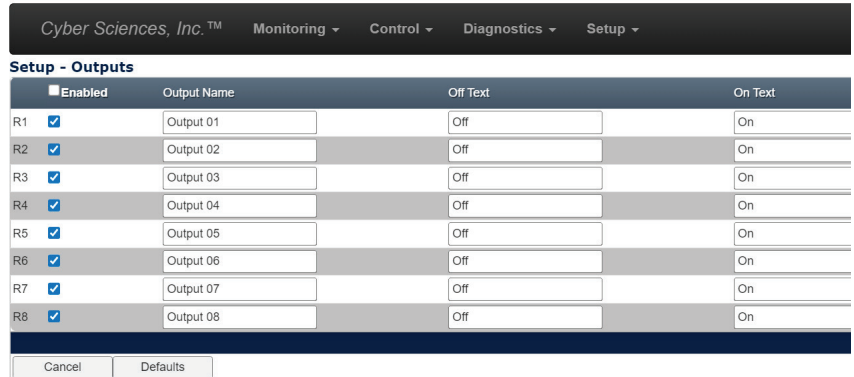

Figure 5-1. Output setup web page (SER-32e)

This web page allows the configuration of each individual output. Configuration parameters include:

Table 5-1— Output configuration settings

Option	Description	Available values	Default
Event Logging	Each output can be enabled for event recording. This does not affect status monitoring—only recording of state changes.	Enabled or Disabled	Enabled
Output Name	Text string (UTF-8) to describe a given output.	32 characters max ①	Output R1, etc.
Off Text	Customized label to describe an Output’s “Off” state.	UTF-8 text string, ① 16 characters max.	Off
On Text	Customized label to describe an Output’s “On” state.	UTF-8 text string, ① 16 characters max.	On
Group Assignment (for Data Logs)	Each output can be assigned to a data log group for reporting purposes	None, or Group 01 to Group 16	None

① Only the following special characters are available: ! @ # \$ % & * () _ - + = { } [] ; . ~ ` ' `

② Setting this time too low (e.g., < 5 ms) can cause unwanted events to be recorded; setting too high (e.g., > 100 ms) can result in missed events.

6—PRODUCT SPECIFICATIONS

Electrical		
Relay Outputs	Number of outputs	8 Form A, solid-state relays
	Signal type	Normally open, true high
	Voltage, operating range	17.5 to 36 Vdc (24 Vdc nominal), Class 2 / LPS
	Current (load) capacity	500 mA per relay output
	Maximum current (surge current)	2 A for 10 seconds, max.
	Leakage current	< 2 μ mA at 24 Vdc
	ON-state voltage drop	< 0.5 volts at 0.5A
	Response time	< 0.1 ms OFF to ON, < 0.1 ms ON to OFF (not including Modbus command)
	Wetting Source	24 Vdc, 4 A max., Class II/LPS
	Fault sensing	Overload and over-temperature (upon removal of fault, output returns to operating state)
	Fault reporting	Fault status available via status LED, LCD, Modbus TCP and web page
	Isolation	Output group to output group: 2 kV Input(s) to output group: 2 kV Output to Earth ground: 2 kV Output to communications interface: 5 kV
Mechanical		
	Mounting	Option slot on SER-32e Sequence of Events Recorder
	Wire sizes supported	#22 to #12 AWG
	Dimensions (W x H x D)	1.26" x 3.65" x 1.71" (32mm x 92.7mm x 43.5mm)
	Dimensions (W x H x D) in packaging	8.0" x 3.0" x 8.0" (203.2mm x 76.2mm x 203.2mm)
	Weight (product alone / product packaged)	0.375 lbs. (0.17kg) / 0.75 lbs. (0.34kg)
Environmental		
	Operating Temperature	-25 to +60 °C
	Storage Temperature	-40 to +85 °C
	Humidity Rating	5% to 95% relative humidity (non-condensing) at +40 °C
	Altitude Rating	0 to 3000 meters (10,000 feet)
	Sustainability / Compliance	RoHS 2 (2011/65/EU), RoHS 3 (2015/863/EU), Pb free California Proposition 65, Low Halogen, Conflict Minerals
Regulatory		
	Safety, USA	UL listed (NRAQ-cULus, UL 61010-1, UL 61010-2-201)
	Safety, Canada	CAN/CSA-C22.2 (61010-1-12, 61010-2-201)
	Safety, Europe	CE Mark (EN 61010-1 : 2010, EN 61010-2-201 : 2017)
	Emissions / Immunity	EN 61326-1 (IEC 61326-1 : 2012)
	Radiated emissions	CISPR 11, Class A, Group 1 (EN 55011) / FCC Part 15B, Class A
	Electrostatic discharge	EN 61000-4-2
	Radiated immunity	EN 61000-4-3
	Electrical fast transient / burst immunity	EN 61000-4-4
	Surge immunity	EN 61000-4-5
	Conducted radio frequency immunity	EN 61000-4-6

7—TROUBLESHOOTING

Symptom	Possible Cause	Suggested Action(s)
Module status LED not ON	Connection issue with SER	Remove power from SER. Remove Output module. Examine the edge connector for damage. Re-insert Output module.
Output(s) not functioning	Wetting voltage or common connection issue or missing. Output connector dislodged. Module control power missing.	Confirm wetting voltage (24 Vdc) and common connections. Ensure Output connector is secured. Check status of module ‘status’ LED. (see below)
Module 24 Vdc LED ‘red’ in color.	Wetting voltage outside acceptable range or connection issue. 24 Vdc common connection issue or missing.	Confirm wetting voltage is in acceptable range (24 Vdc). Confirm 24 Vdc common connection.
Output status for Outputs 33-40 is reporting as disabled.	No output module installed in option slot #1.	There is no issue using option slot #2 and not using option slot #1. For sequential output numbering, move the Output module to option slot #1. NOTE: you will need to reconfigure the output module when moving it from option slot #2 to slot #1.



Cyber Sciences, Inc. (CSI)
229 Castlewood Drive, Suite E
Murfreesboro, TN 37129 USA
Tel: +1 615-890-6709
Fax: +1 615-439-1651



Doc. no: IB-eXM-02
May -2023

The service marks, "Precision Timing for Reliable Power. Simplified.," CyTime, and the Cyber Sciences stylized logo are trademarks of Cyber Sciences. All other trademarks are the property of their respective owners.